



Huskisson 12 Park Street

\$1,595,000

MODERN HUSKYLIFE



Properties such as this one are so often sought, but are rarely found in the trendy town of Huskisson. Modern contemporary design and master built by renowned local builder, David Reid Homes. Offering the beachy cottage feel combined with all the creature comforts of modern living.

- Perfect for retirement and ideal for holiday accommodation.
- Maybe use for both with hallway lock-off for two bed flat
- with separate entry, private al-fresco and off street parking.
- Single level home sitting on a huge 923m² flat corner block.
- Architectural design, raked ceilings, indoor/outdoor fusion.
- Lounge/living flows seamlessly to north/east facing al-fresco.
- Deluxe stone kitchen, huge five seat breakfast bar, gas cooking.
- Formal lounge/TV room plus a handy music room/home office.
- Resort style landscaping with tropical plants and mature trees.
- Footsteps to cafes, restaurants and the main street of Husky.

Located just 260mtrs from Currambene Creek access for your Stand Up Paddle Board, Kayak or Canoe and approx 400mtrs to the centre of "The Main Street" with Restaurants, Cafes, Dolphin and Whale watching Cruises, RSL, The Pub and much more.

All Enquiries or to book a private inspection please contact Scott Morton on either 0405 227 987 or 0244 417 514.



Scott Morton
0405 227 987
0244 417 514
scott@jervisbayproperties.com.au



Vital Statistics

Block size 923.0m²

EER

Feature List

- 4 Bedrooms
- 3 Bathrooms
- 2 Garages
- 1 Carports

Block Map

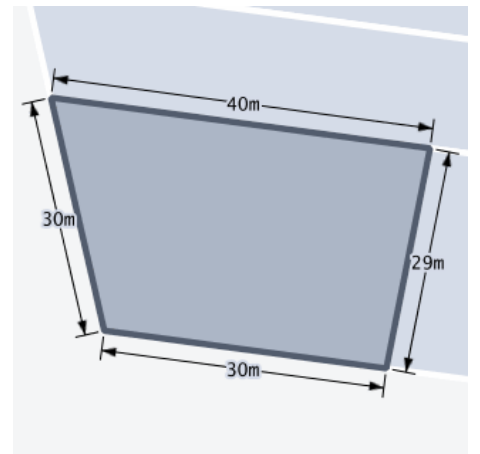

Disclaimer

This report has been compiled by All Homes Pty Ltd (ACN 093 012 652). Information within this report is supplied in large part by third parties. While All Homes attempts to publish information in good faith: All Homes and information providers provide no guarantees, undertakings or warranties regarding the correctness, comprehensiveness or up-to-dateness of information, or its fitness for any user pays purpose; Users are advised to corroborate information at their discretion; Circumstances changed post-publication can alter information accuracy, and All Homes does not assure the information accuracy or guidance therein contained. Access to this report is subject to All Homes Terms & Conditions which can be viewed at <http://www.allhomes.com.au/ah/ah0011>